



TRANSFORMING INSIGHTS INTO EXECUTION

Asset Protection Solutions

Asset Protection Solutions

Table of Contents

At enVision we are obsessed with helping retailers protect their assets while helping brands convert shoppers into customers at the same time.

We carefully consider the needs of the retailers, the brands, as well as the desires of the shopper, and develop solutions that serve all three.

We offer a complete line of asset-protecting solutions, including custom displays, enclosures, door kits, and accessories that allow retailers to protect their assets while engaging shoppers.

In-Line Solutions

Gondola Security Locking Door Kit 42

Breach-Resistant Gondola Door Kit 44

Drop-in Inline Enclosure 46

Gondola Base Deck Locking Drawer 48

Shelf Solutions

Pilfer-Proof Locking Case 50

One 2 Show - One 2 Go Locking Case 52

Anti-Sweep Laundry Lock 54

Anti-Sweep Shelf Barrier 56

Target Ulta Security Case 58

Stadium Cascade Shelf Fixture 60

Endcap Solutions

Drop-in Endcap Enclosure 62

Acrylic Endcap Locking Box 64

Freestanding Solutions

Freestanding Security Endcap 66

Pilfer-Proof Locking Tower 68

Gondola Security Locking Door Kit*

In-Line Solutions



Our Gondola Security Locking Door Kit attaches to any stock gondola and converts it into a secure asset protecting enclosure. Robust design is engineered to withstand pry-bars and deters even the most motivated shoplifter from accessing the contents.

patent pending

Gondola Security Locking Door Kit* COMPONENTS

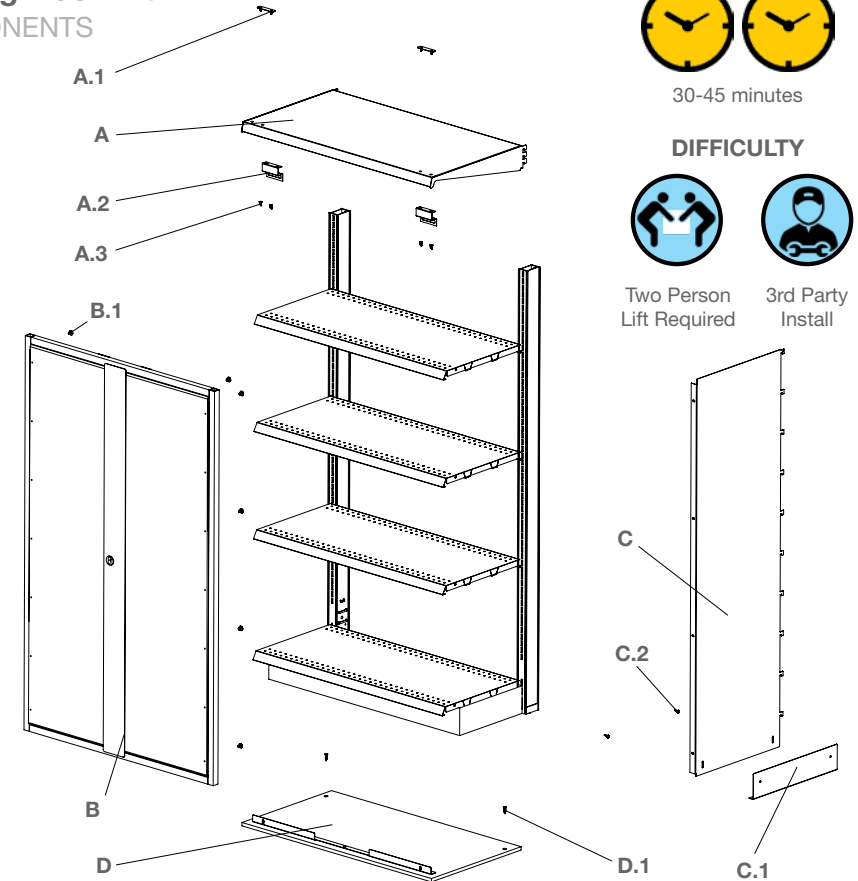

- | | | | |
|------------|------------------------------|------------|-----------------------------------------|
| A | 36 x 18 Cap | C | End-of Run Side |
| A.1 | Cap Bracket | C.1 | Extender (Preattached) |
| A.2 | Frame Bracket | C.2 | Extender Wing Nuts (Preattached) |
| A.3 | Cap Bracket Wing Nuts | D | Base Deck |
| B | Door Kit | D.1 | Deck Screws |
| B.1 | Door Frame Bolts | | |

INSTALL



30-45 minutes

DIFFICULTY



Two Person
Lift Required

3rd Party
Install

TRANSFORMING INSIGHTS INTO EXECUTION



FEATURES / BENEFITS

- Universal Mounting Fits All Gondolas
- Breach-Resistant design prevents pry bar access
- Shatter-Proof polycarbonate doors - doors pre-installed for easy assembly at store level
- SFIC compatible kit accomodates customer-supplied locks
- Modular kit dresses any run length with no walls between sections

Breach-Resistant Gondola Door Kit*

In-Line Solutions



Our Breach-Resistant Gondola Door Kit attaches to stock Lozier or Madix gondola shelves and converts them into a secure asset protecting enclosure. Robust design is engineered to withstand pry-bars and deters even the most motivated shoplifter from accessing the contents.

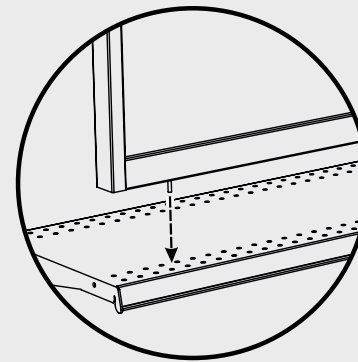
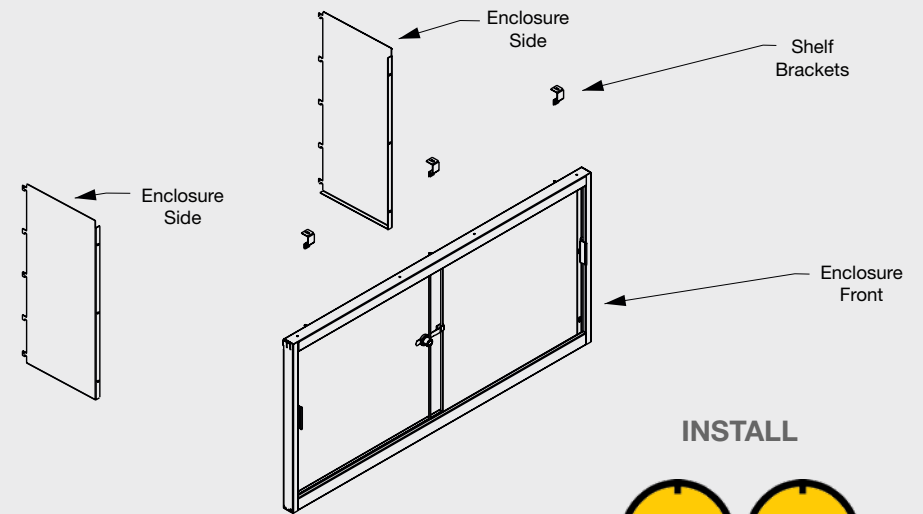

INSTALL



30-45 minutes

DIFFICULTY



Two Person Lift
Required



Store Associate
Install



Tools Required

TRANSFORMING INSIGHTS INTO EXECUTION



53" Kit
*patent pending

FEATURES / BENEFITS

- Attaches to stock Lozier and Madix gondolas
- Breach-Resistant design prevents pry bar access
- Available in 24" and 53" heights - custom sizes available upon request
- Impact-Resistant tempered glass doors - 1/4" thick
- Door kit ships with doors pre-installed
- Anodized aluminum door pulls
- Interior shelves must be 2" shorter than base deck & upper shelf for installation
- Accommodates customer-supplied SFIC locks



Breach-Resistant Security

Our PATENT PENDING solution is engineered to prevent pry bar break-ins & minimize loss



Quick & Easy Installation

Door kits install in as little as 5 minutes with minimal parts and complexity



Reduced Components

Optimized design requires minimal hardware to install - parts kit contains only 6 items

Drop-In Inline Enclosure*

In-Line Solutions

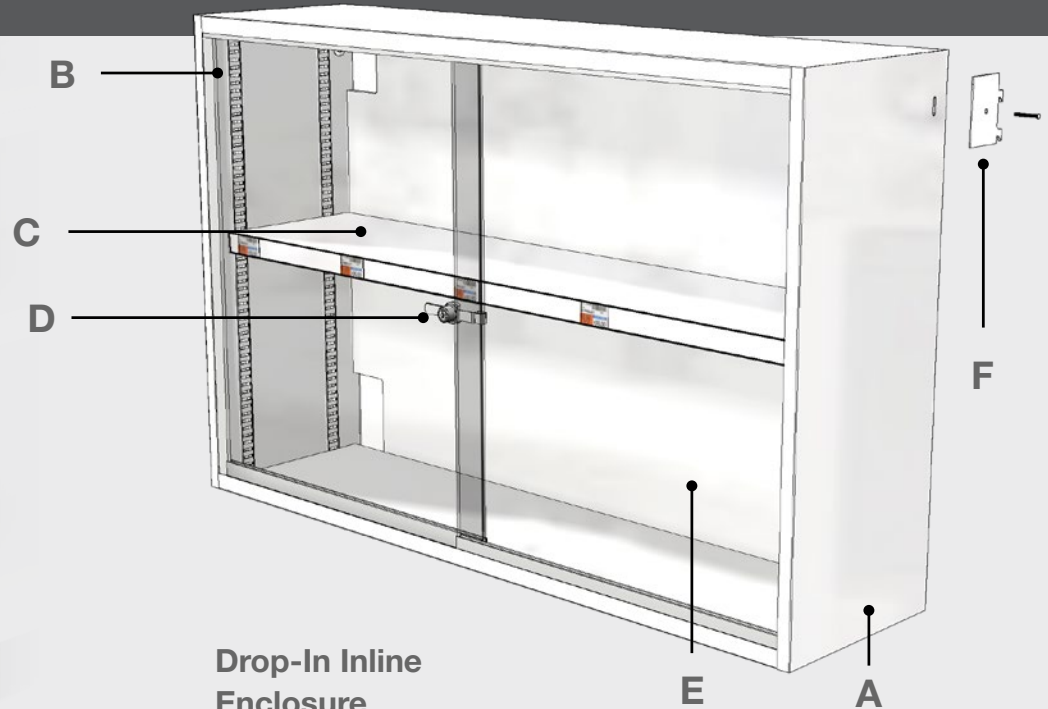

Drop-In Inline Enclosure COMPONENTS

- A. STEEL BODY
- B. SHELF TRACK
- C. ADJUSTABLE SHELF
- D. LOCK
- E. TEMPERED GLASS DOORS
- F. SECURITY BRACKET

INSTALL



30-45 minutes

DIFFICULTY



Two Person Lift Required



Store Associate Install



No Tools Required

A plug & play enclosure ships fully assembled and secures to any gondola base deck or shelf. Interior shelves adjust in 1/2" increments.

*patent pending

TRANSFORMING INSIGHTS INTO EXECUTION



Drop-In Inline Enclosure can be equipped with a kit of accessories to customize the case to your preferred brand presentation.

*patent pending



ENCLOSURE HEADER

- Mounts to top of enclosure and includes a changeable graphic
- Available in 3ft or 4ft widths (custom sizes available)
- 3” changeable graphic holder



LED LIGHTING

- LED light bar mounts to underside of shelving
- Light bars can string together to light multiple shelves
- Magnetic attachment makes lighting easy to install



WINDOW CLING GRAPHICS

- Printed decals attach to the glass doors of standard enclosures
- Decals provide additional space for brand claims or graphics to dress encasement (frost texture, patterns, etc.)
- Customized to meet your needs



SUB HEADER

- Mounts to interior shelves to provide additional messaging space
- 2” changeable graphic (standard) Graphic size can be customized depending available interior space
- Dual channel provides space for standard retailer price labels



END CAP / SIDE PANEL SHROUD

- Mounts to top of enclosure and includes a changeable graphic
- Available in 3ft or 4ft widths (custom sizes available)
- 3” changeable graphic holder



SHELF EDGE INSERT

- Insert drops into existing shelf channel to provide color or printed patterns behind retailer price labels
- Larger inserts can stick out of channel for messaging space
- Made of plastic or cardstock depending on application

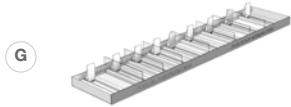

STANDARD MERCHANDISING TRAY

- Merchandising Tray sits on shelf inside enclosure
- Tray keeps product organized for improved presentation
- Adjustable dividers and product pushers keep product faced
- Changeable graphic strip on front of tray



RISER MERCHANDISING TRAY

- Riser tray prevents obstructed view of product behind door track on bottom shelf
- Adjustable dividers and product pushers keep product faced
- Changeable graphic strip on front of tray

Gondola Base Deck Locking Drawer*

In-Line Solutions



*patent pending

Innovative enclosure converts space underneath a gondola base deck into a secure backstock storage solution that helps streamline replenishment at shelf level and frees up space in the back room.

INSTALL



60-90 minutes

DIFFICULTY



3rd Party Install

**Base Deck
Locking Drawer***

COMPONENTS

*patent pending

A. KICKPLATE WITH KEYHOLE

B. STORAGE COMPARTMENT

C. LATCH MECHANISM

D. DRAWER SLIDE

E. ADAPTER PLATE

(VARIES BY GONDOLA MANUFACTURER)

FEATURES / BENEFITS

- Heavy-duty steel construction
- Auto locking feature doesn't require turn of a key to secure contents
- Kick-To-Close latching means less strain on store associates to use
- Universally adaptable for all standard gondola systems

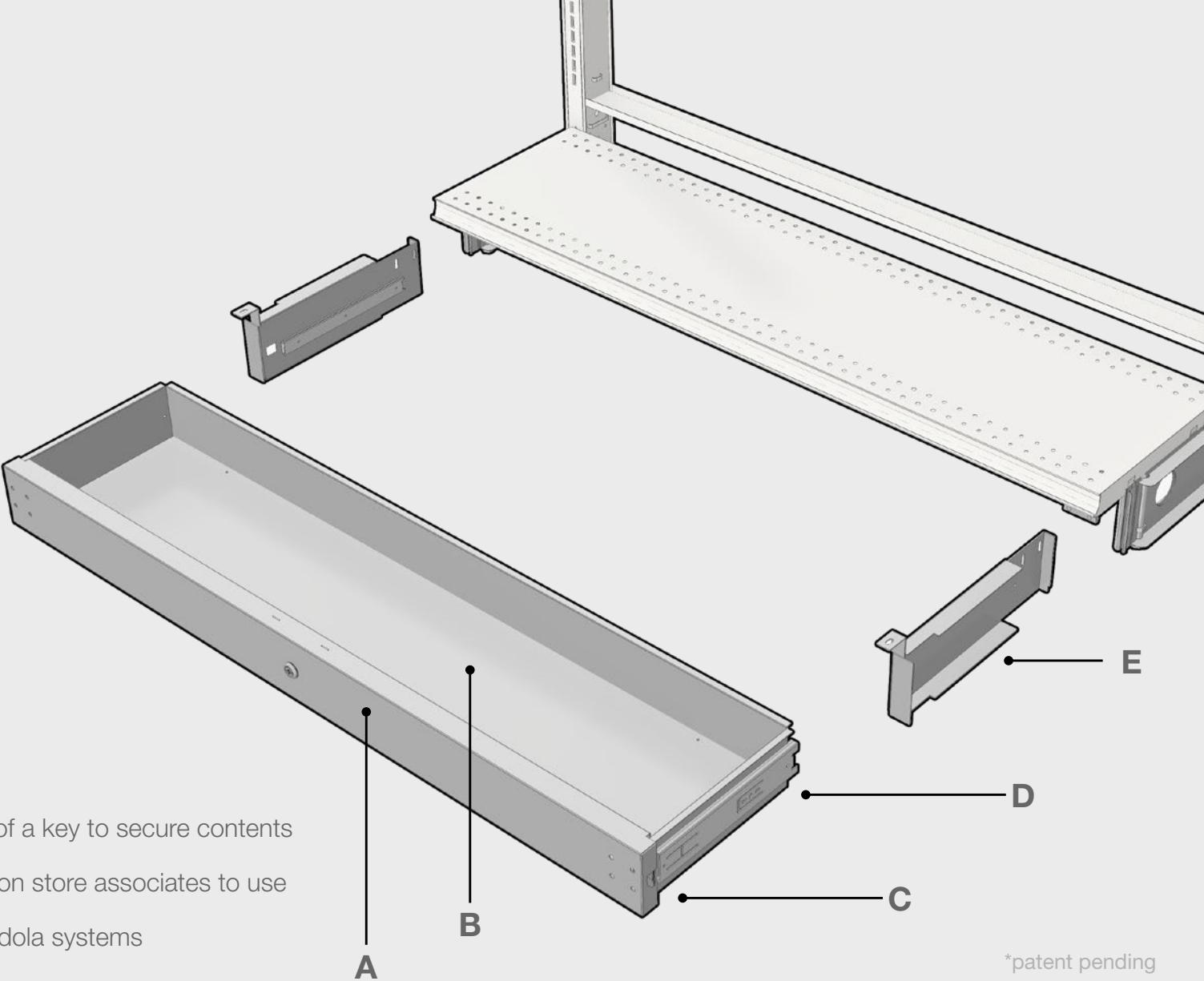

*patent pending

Pilfer-Proof Locking Case*

Shelf Solutions

Pilfer-Proof Locking Case

COMPONENTS

*patent pending

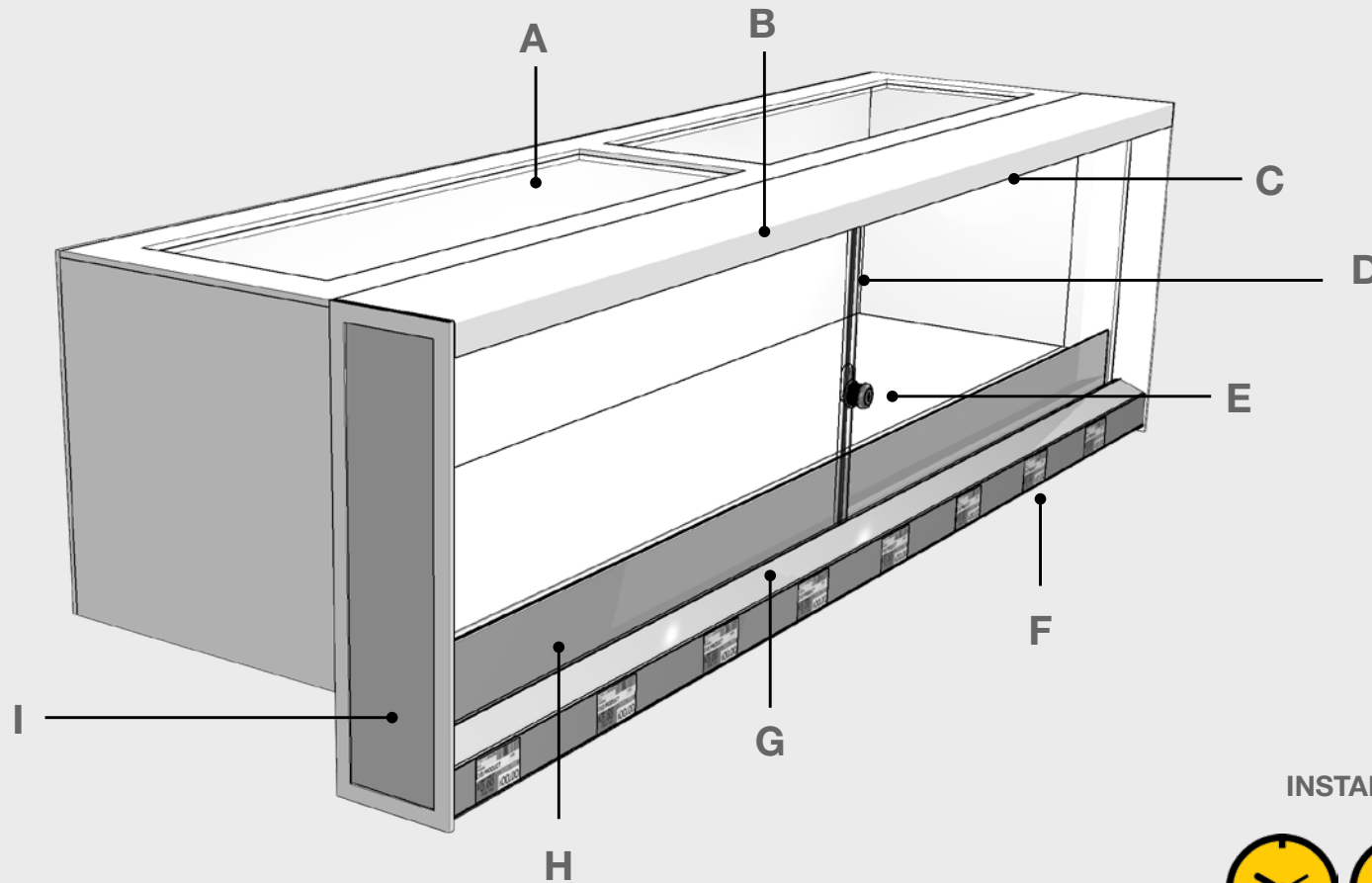

A. SKYLIGHT

B. OPTIONAL HEADER GRAPHIC (NOT ILLUSTRATED)

C. OPTIONAL LED LIGHTING

D. ACRYLIC DOORS

E. RATCHET LOCK

F. PRICING CHANNEL

G. RAMP GRAPHIC

H. OPTIONAL SUB HEADER

I. SIDE WING GRAPHIC

INSTALL



30-45 minutes

DIFFICULTY



Two Person Lift
Required



Store Associate
Install



No Tools
Required

TRANSFORMING INSIGHTS INTO EXECUTION

The Pilfer-Proof Locking Case is self-contained asset protection solution for in-line and endcap applications. Fasteners are accessed from behind the doors to prevent tampering. This ADA compliant case can be dressed with your graphics for a branded security solution.



*patent pending

FEATURES / BENEFITS

- Durable Sheet Metal Construction
- Fast Installation / Arrives Fully Assembled
- Bright and Inviting Product Presentation
- Prominent Branding Visible From All Viewing Angles
- Forward Compatible Design Allows For Cost-Effective Rebranding
- Universal Mounting Fits All Gondolas

One-To-Show Locking Case*

Shelf Solutions

One-To-Show Locking Case*

COMPONENTS

*patent pending

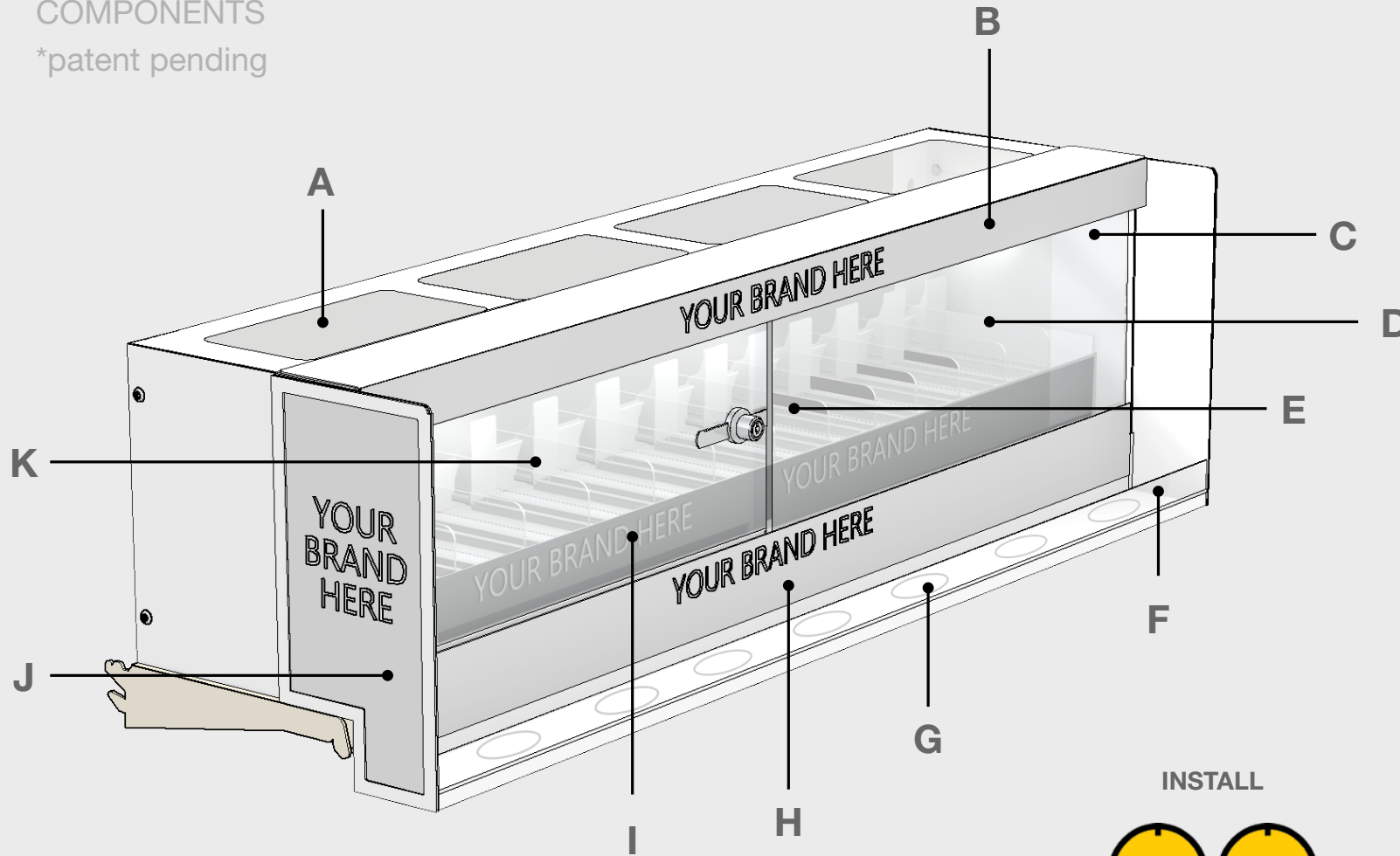

- A. SKYLIGHT
- B. OPTIONAL HEADER GRAPHIC
- C. OPTIONAL LED LIGHTING
- D. ACRYLIC DOORS
- E. RATCHET LOCK
- F. PRICING CHANNEL
- G. PRODUCT LOCATING PANEL (OPTIONAL)
- H. SHELF BACKER GRAPHIC
- I. RISER GRAPHIC
- J. PUSHER SYSTEM (OPTIONAL)
- K. SIDE WING GRAPHIC

INSTALL



30-45 minutes

DIFFICULTY



Two Person Lift
Required



Store Associate
Install



No Tools
Required

TRANSFORMING INSIGHTS INTO EXECUTION

The One-To-Show Locking Case is self-contained asset protection solution. This unique solution features an ADA compliant shelf that holds a single facing for purchase, tester product, or dressed for a touch & learn product experience.



FEATURES / BENEFITS

- Durable Sheet Metal Construction
- Keeps One High Value SKU Available While Protecting Backstock
- Promotes An Interactive Shopping Experience
- Fast Installation / Arrives Fully Assembled
- Prominent Branding Visible From All Viewing Angles
- Forward Compatible Design Allows For Cost-Effective Rebranding
- Universal Mounting Fits All Gondolas



Anti Sweep Laundry Lock*

Shelf Solutions

Our Patent Pending Anti-Sweep Laundry Lock secures bottles on shelf with a hook-mounted puck that traps bottles at the handle. Lock is opened by store associates with a standard Alpha Key. The custom peghook design allows locks to easily be installed; even on lower gondola shelves to protect bottled merchandise. Puck labels can be customized with your own graphics or branding.



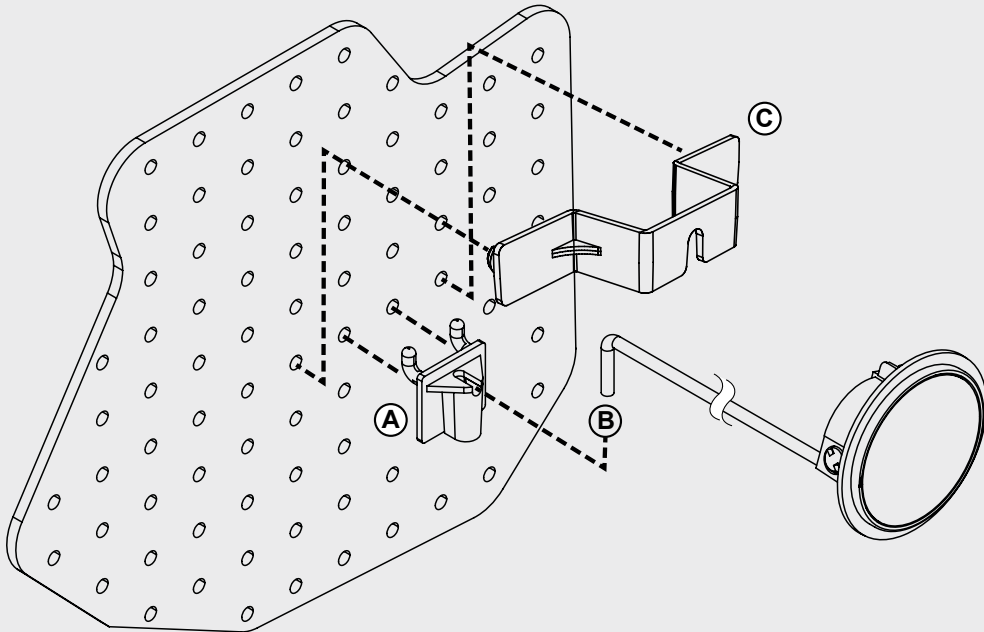

Easy Installation

- 1. Hook Wire Mount (A) into Pegboard
- 2. Slip the end of Wire (B) into the Wire Mount.
- 3. Fit the Retainer (C) over the Wire and press it into the Pegboard holes on each side of the Wire Mount.

INSTALL



1-5 minutes

DIFFICULTY



Store Associate
Install



Also works with dispenser bottles!



Anti-Sweep Hinged Shelf Barrier*

Shelf Solutions



Anti-Sweep solution features hinged clear PETG doors limit access to merchandise without obstructing view of product on gondola shelves. Spring loaded hinges allow shelf barriers to self-close and reduce sweeping.

FEATURES / BENEFITS

- Hinged clear plastic shelf barriers
- Spring loaded hinges / self-closing barrier
- Outward opening doors don't interfere with product on shelf
- Easily installed with a screwdriver
- Pricing ticket channel with optional graphic insert
- Powdercoated steel frame

INSTALL



30-45 minutes

DIFFICULTY



3rd Party
Install

TRANSFORMING INSIGHTS INTO EXECUTION

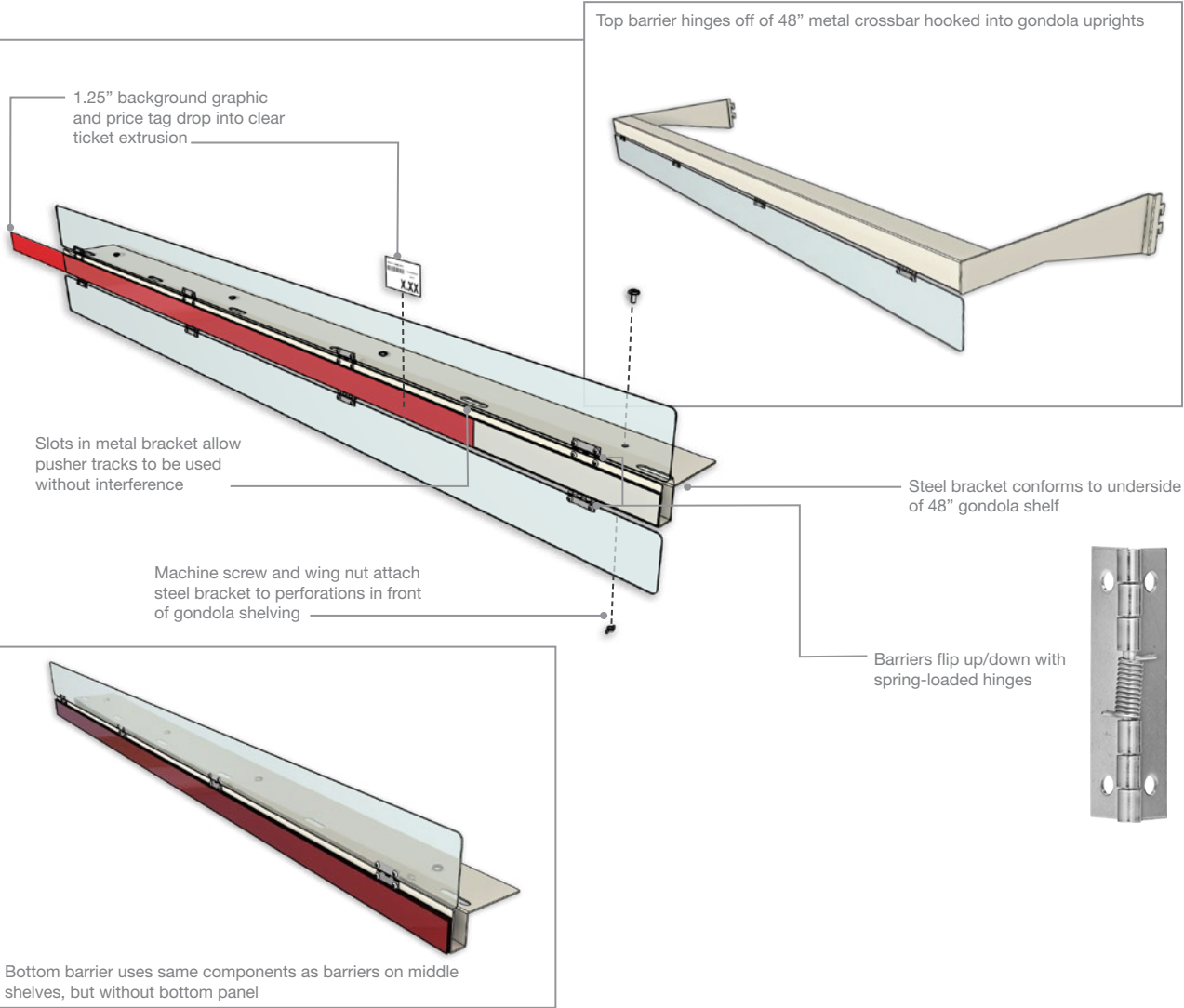
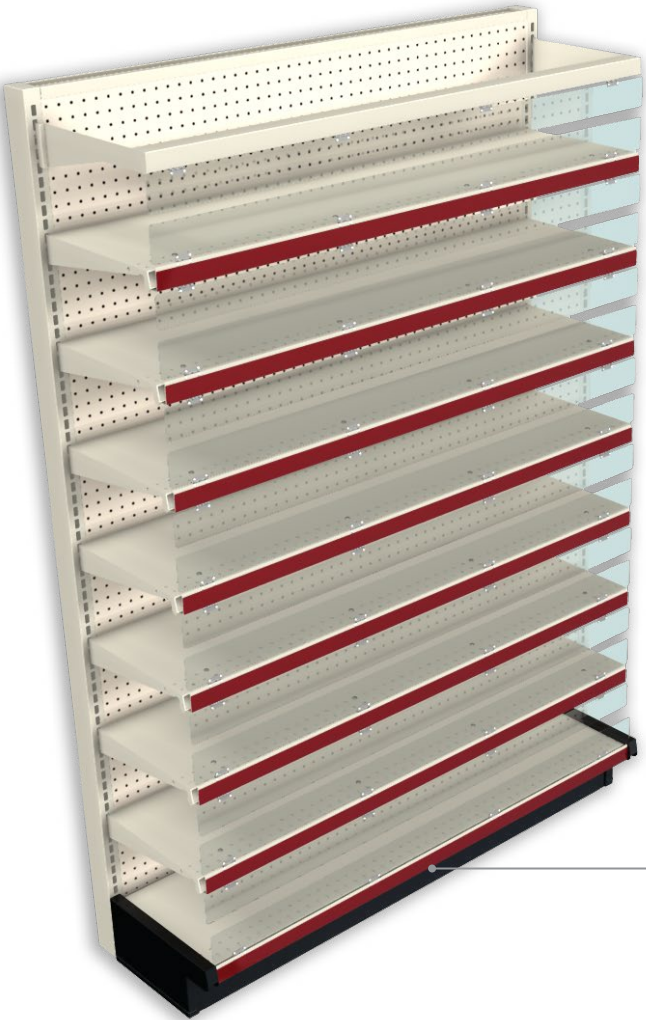

Target Ulta Security Case

Shelf Solutions



This retrofit shelf security solution was developed for Target to secure the assets in their Ulta shop-in-shop locations.

Security case needed to attach to the existing store shelves without mechanical fasteners or damage to the shelves.

This solution featured an innovative clamp-like architecture that created a locking shroud around each 24" wide shelf.

FEATURES / BENEFITS

- Mounts to existing shelves without mechanical fasteners
- Clear polycarbonate encasement & door panel
- Bottom-hinged door for easy restocking / product access when open
- Heavy-duty steel construction
- SFIC compliant lock

TRANSFORMING INSIGHTS INTO EXECUTION

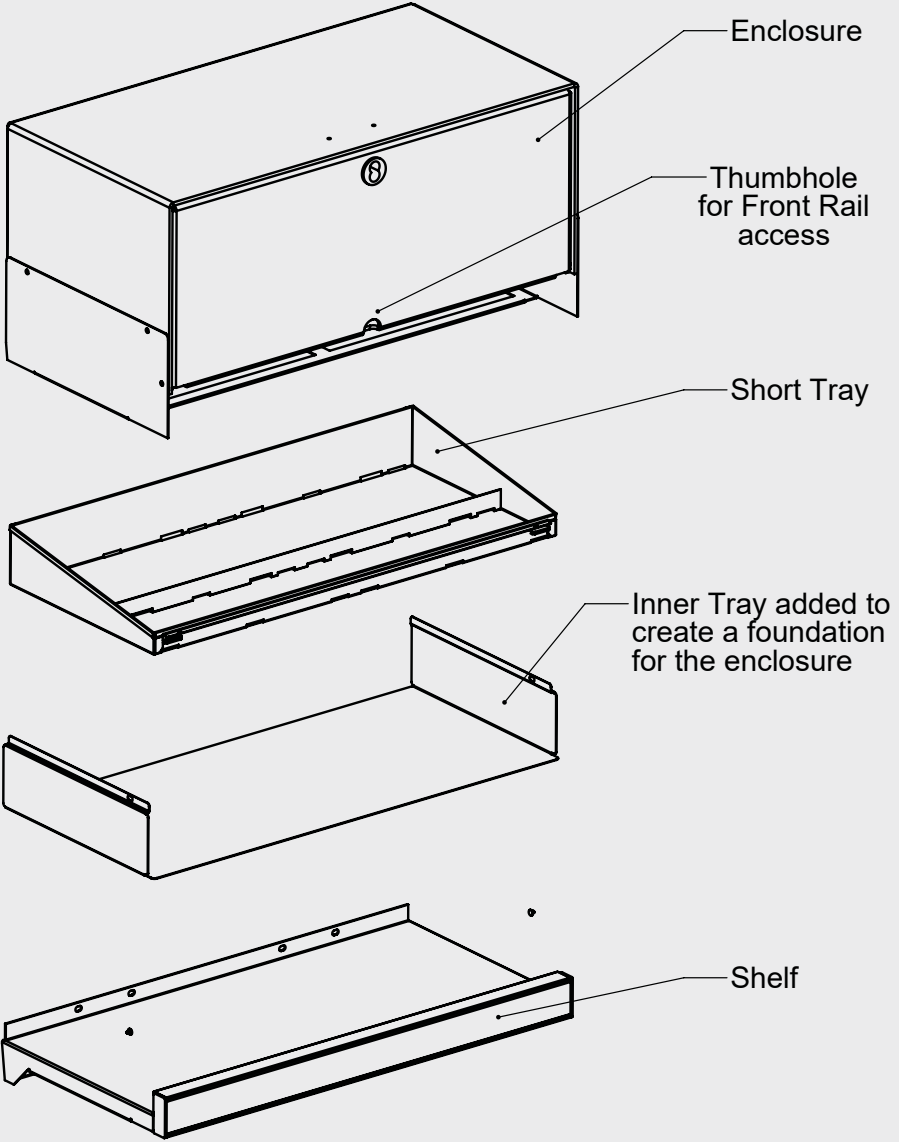

Stadium Cascade Shelf Fixture

Shelf Solutions



- Drop-in inline enclosure features an articulating drawer that receives custom product / tester inserts and a locking case that secures sellable merchandise
- Sliding drawer extends 12" into aisle bringing locking case flush to front edge of inline fixture to allow easy access to merchandise
- Clear acrylic locking case pulls forward to allow easy access to product when opened by store personnel
- Durable steel / composite construction

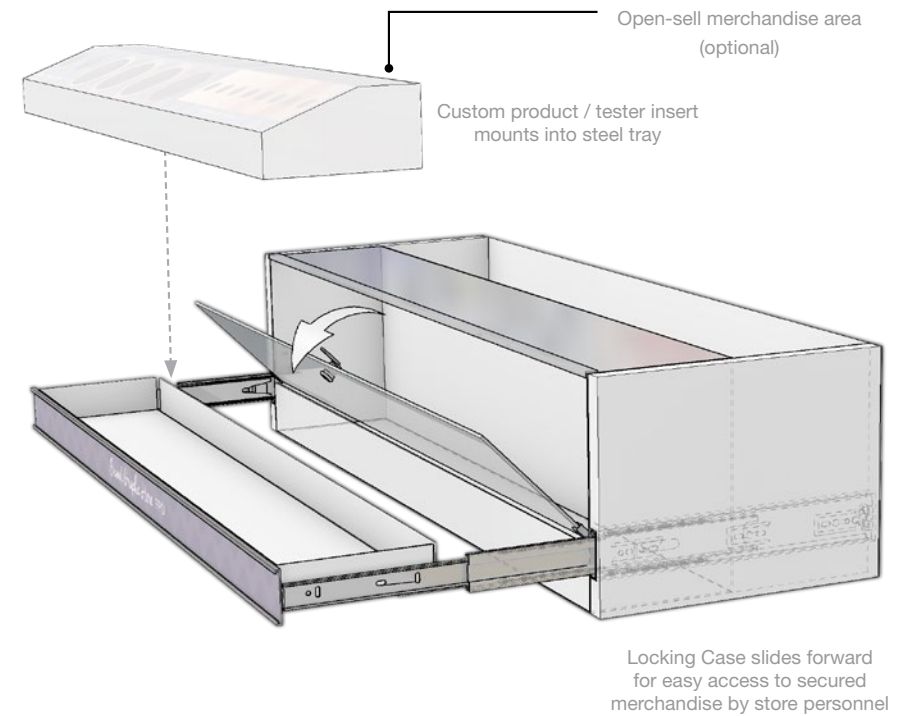

TRANSFORMING INSIGHTS INTO EXECUTION



Door opens down for access to locked merchandise / backstock

Drop-In Endcap Enclosure*

Endcap Solutions

Our Drop-In End Cap Enclosure converts a traditional endcap into a secure vehicle to drive sales in a highly visible location. Completely self-contained construction means this case comes out of the box fully assembled and ready to merchandise your products in a highly visible location.

Drop-In Endcap Enclosure

FOR CVS ELEVATED ENDCAP

This Crest 3D Whitestrips Endcap features our Drop-In Locking Case. The install was upgraded to feature battery-powered LED lighting with a motion sensor, as well as a graphic easel with a mirror that encouraged the shopper to “compare your smile”.

INSTALL



30-45 minutes

DIFFICULTY



Two Person Lift
Required



Store Associate
Install



No Tools
Required



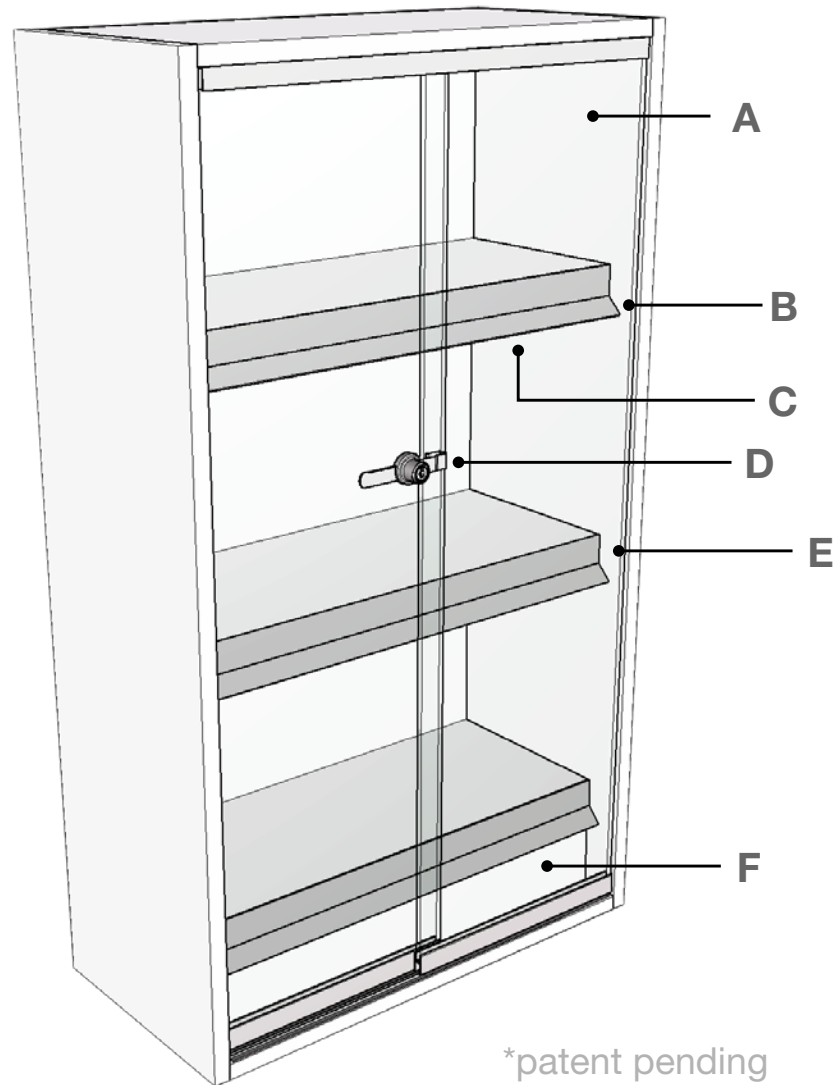

Drop-In Endcap Enclosure COMPONENTS

- A. TEMPERED GLASS DOORS
- B. PRICING CHANNEL
- C. OPTIONAL LED LIGHTING
- D. RATCHET LOCK
- E. CHANGEABLE SHELF STRIP
- F. BASE RISER

FEATURES / BENEFITS

- Fast Installation / Arrives Fully Assembled
- Multitude of Branding & Product Presentation Options
- Allows Brands to Feature Their Premier Products While Retailers Protect Their High-Value Assets

Acrylic Endcap Lock Box*

Endcap Solutions

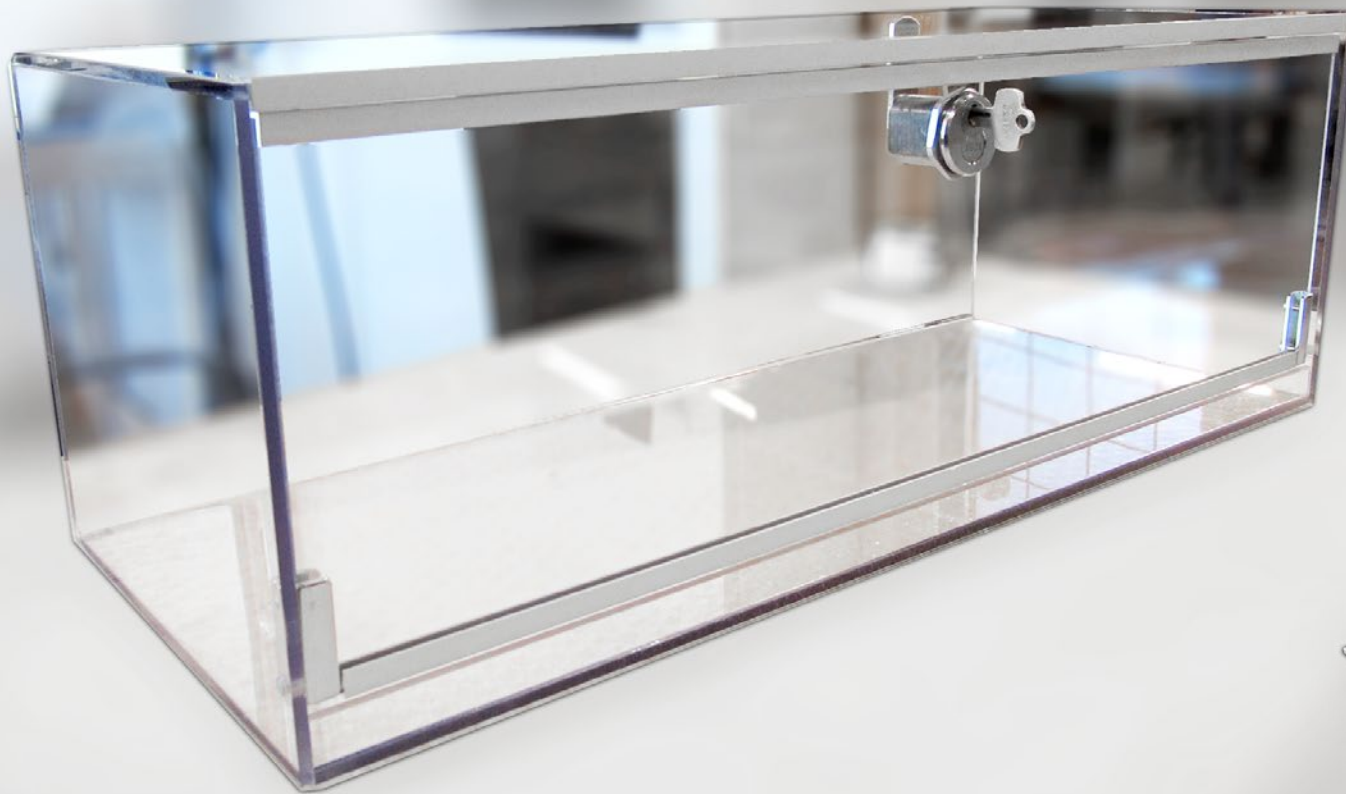

Basic but effective, our acrylic locking boxes can be made to accommodate a wide range of needs. This lockbox was designed with a door that opens down to allow easier access to the product contained inside.

INSTALL



10-15 minutes

DIFFICULTY



Store Associate
Install



No Tools
Required

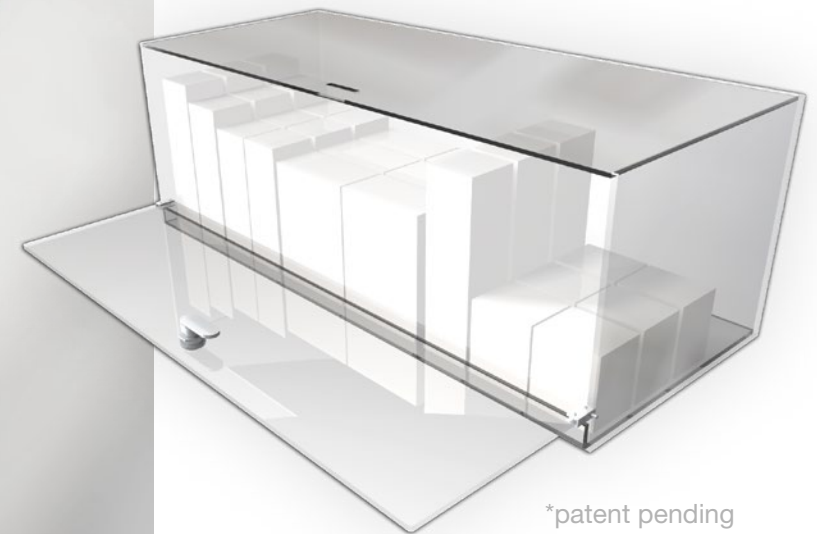

*patent pending

TRANSFORMING INSIGHTS INTO EXECUTION

Steel bracket provides extra level of security by anchoring lockbox to gondola shelf

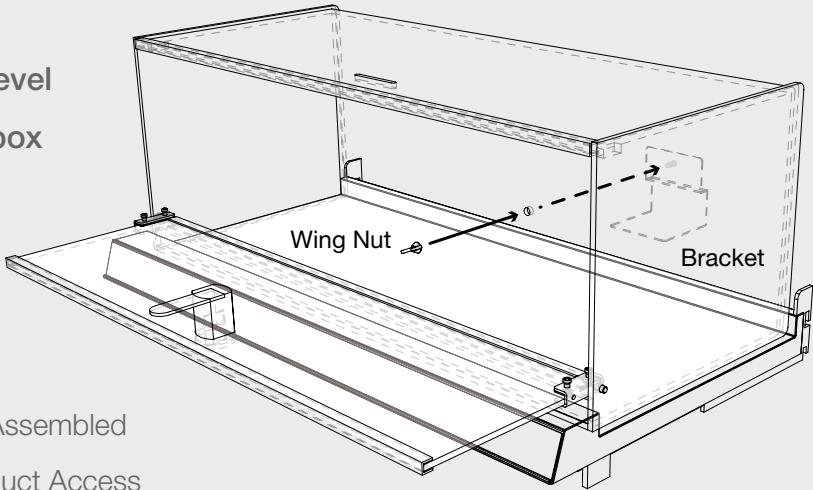

FEATURES / BENEFITS

- Fast Installation / Arrives Fully Assembled
- Fold Down Door For Easy Product Access
- Bright / Clear Product Presentation
- Available in 2ft, 3ft, & 4ft widths

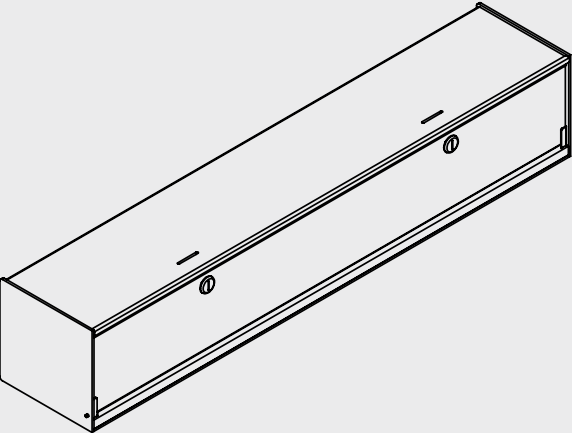

Also available in 4ft widths



Freestanding Security Endcap*

Freestanding Solutions



This freestanding fixture protects your assets while providing a large shelf to display demo products or other display elements.

Personal Electronics Endcap

We used our freestanding security endcap as part of this interactive tablet display. The endcap was enhanced with the inclusion of a lightbox graphic backer and edge-lit 3D brand logo. This endcap also utilized security tethers that provided power to the demo products.

INSTALL



30-45 minutes

DIFFICULTY



Two Person
Lift Required



3rd Party
Install

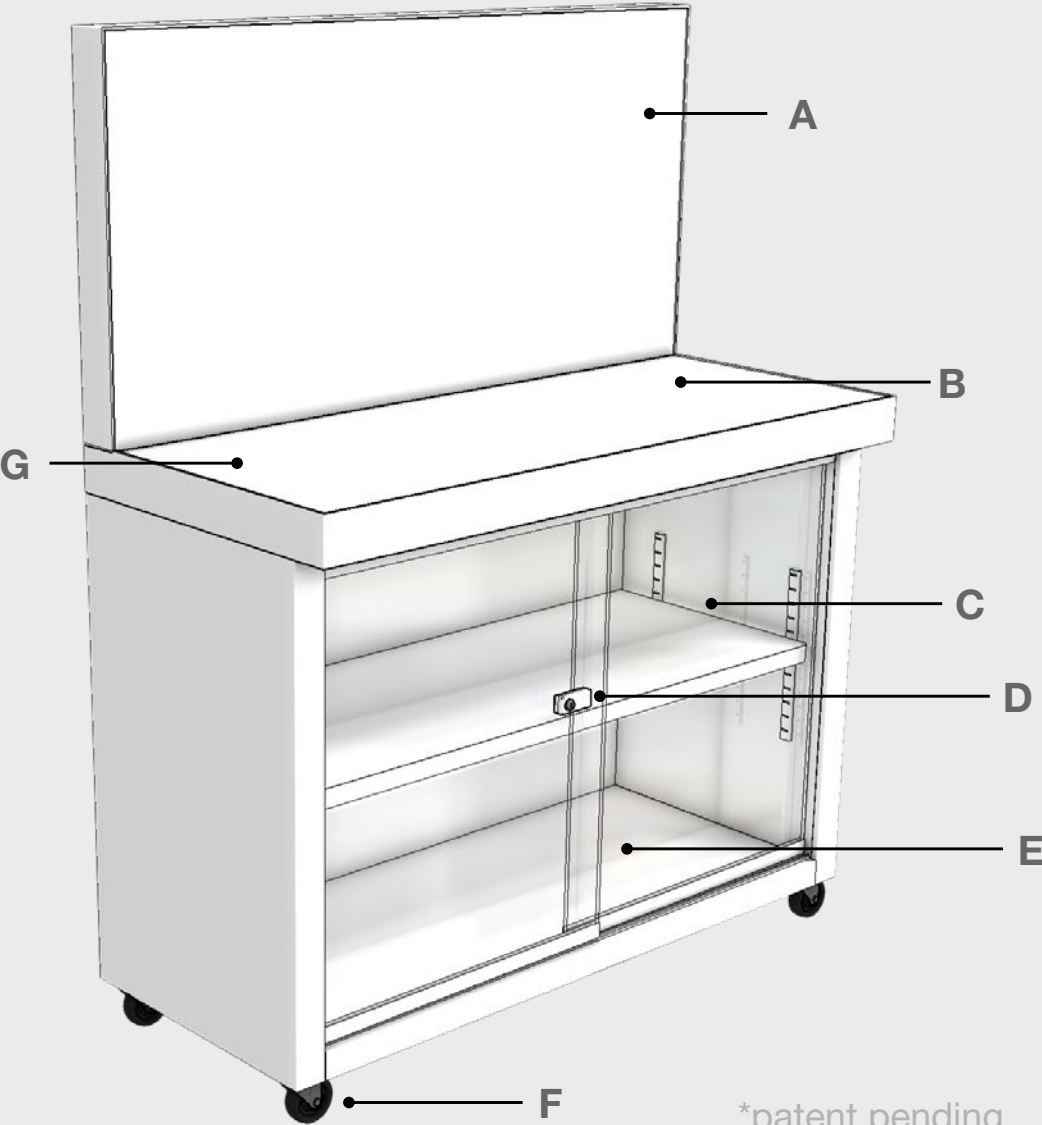

Freestanding Security Endcap COMPONENTS

- A. BACKER
- B. SHELF
- C. ADJUSTABLE SHELF
- D. PREMIUM LOCK
- E. TEMPERED GLASS DOORS
- F. LOCKING CASTERS
- G. OPTIONAL SECURITY TETHERS
(NOT ILLUSTRATED)

FEATURES / BENEFITS

- Fast Installation / Arrives Fully Assembled
- Promotes An Interactive Shopping Experience
- Allows Retailer to Keep High-Value SKUs Available For Test While Protecting Their Salable Inventory
- Forward Compatible Design Allows For Cost-Effective Rebranding

*patent pending

Pilfer-Proof Locking Tower

Freestanding Solutions



Fully assembled encasement displays product behind a secure door and tempered glass panels trimmed with steel and melamine. A large locking door allows for easy access and restocking of four adjustable shelves. The display interior is illuminated by LED puck lights mounted inside the header. Kneeling casters allow the tower to be moved into position and then elevated on rubber pads reducing mobility and preventing full case loss.

FEATURES / BENEFITS

- Heavy-duty steel construction
- SFIC compliant lock
- Kneeling casters prevent display from being removed from position
- Tempered glass doors / shelves (other options available)
- Tower can be equipped with optional tether rail(s) for extra security
- Optional LED lighting

INSTALL



30-45 minutes

DIFFICULTY



Two Person Lift
Required



Store Associate
Install



No Tools
Required

Easy Shelf Installation

- 1. Unlock doors and insert shelf pins
- 2. Pivot glass shelves to place inside case & set onto 4 shelf pins

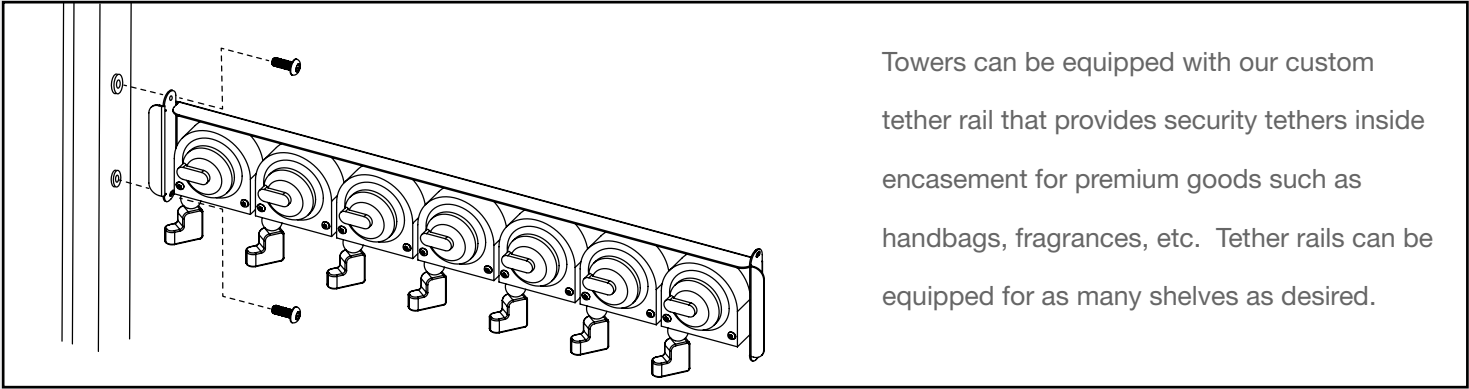
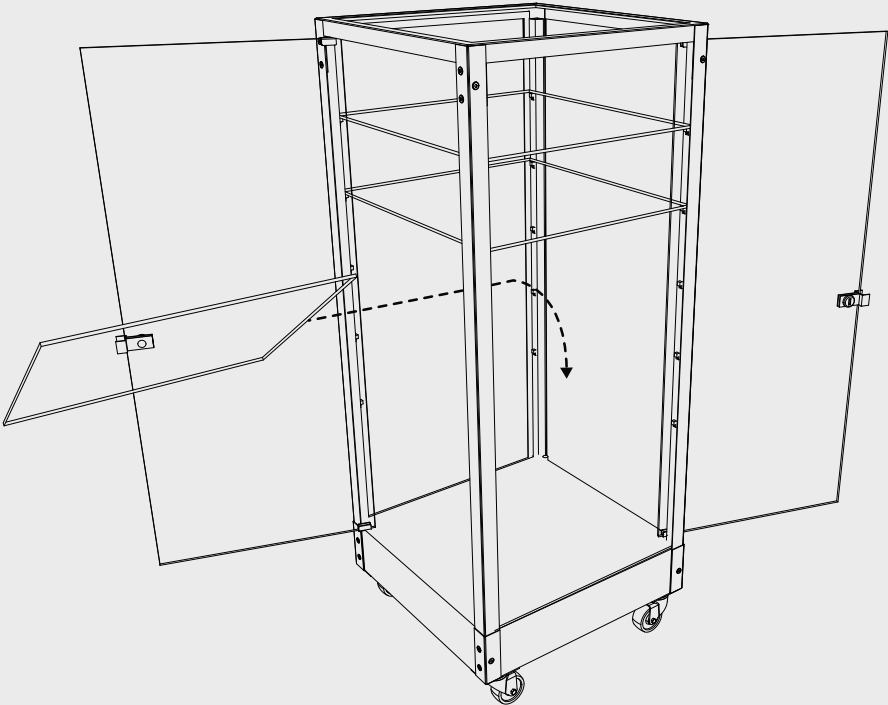

Towers can be equipped with our custom tether rail that provides security tethers inside encasement for premium goods such as handbags, fragrances, etc. Tether rails can be equipped for as many shelves as desired.





we're ready for retail™



www.envisionsolutionsgroup.com